

SCHEMA TECNICA

Technical sheet

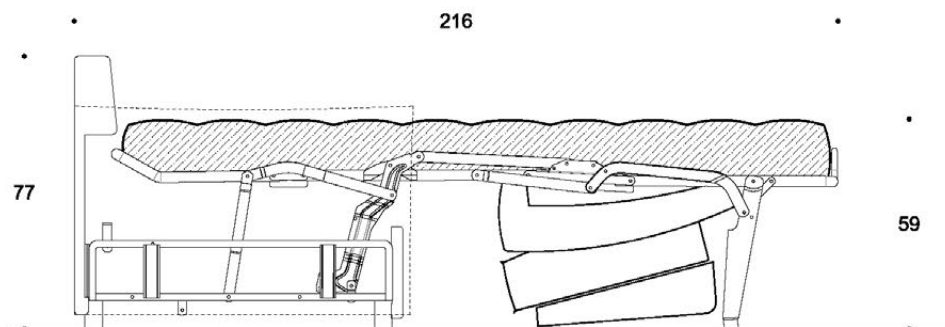
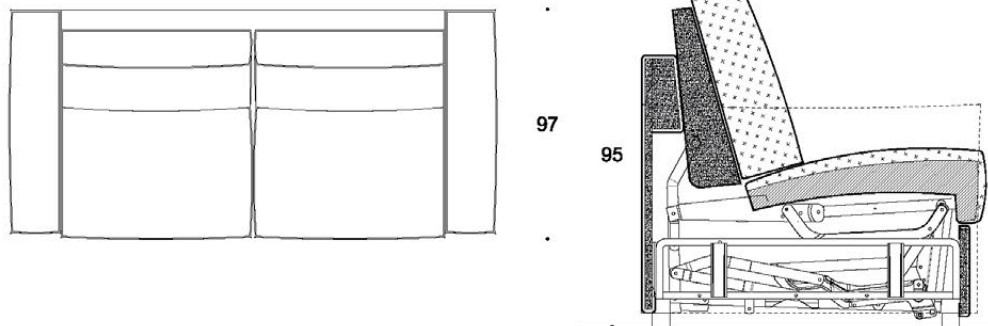
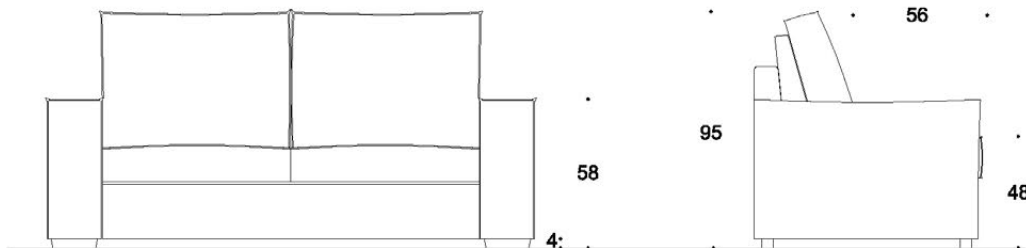

Fusto in legno
Wooden frame

Miscela di piuma e fibra siliconata
Blend of feather and silicone fiber

Poliuretano elastico 30 kg/m³
30 kg/m³ elastic polyurethane foam

Tessuto / Pelle
Fabric / Leather

CARATTERISTICHE FEATURES

- Materasso - Mattress:
Luxury memory h 17
- Rivestimento sfoderabile
Removable cover
- Portaguanciali
Pillows storage
- Imbottitura in piuma
Feather padding
- Cucitura E
Stitching E
- Piedini in legno
Wooden feet



OPTIONAL



Roller E-motion



Woody



Imbottitura seduta rigida
Firm seat padding



Ignifugo
Flame retardant